

## PRODUCT DATASHEET

# I-FLEX LP FLANGE INSULATING SET

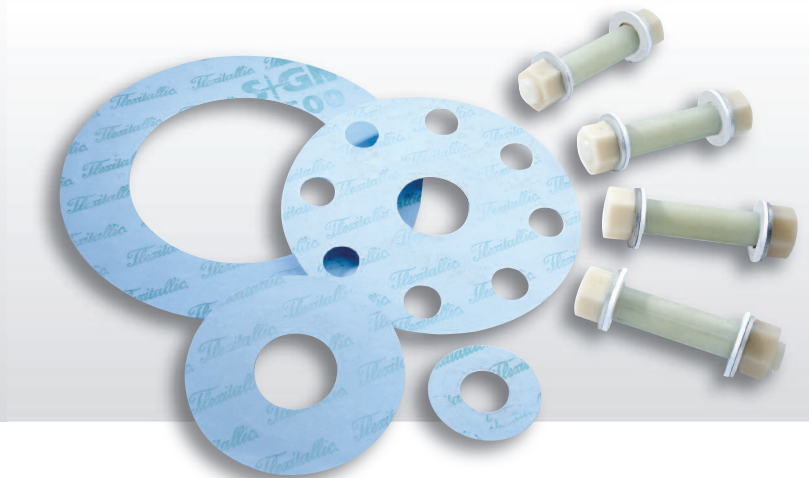

The Flexitallic I-Flex Flange Insulating Set (LP) is comprised of an Insulating Gasket, Insulating Sleeves, Insulating Washers and Metal Washers.

The Insulating Gasket is a 3mm soft cut Sigma® 500 material.

**Colour:** Blue

**Service:**

The Flexitallic I-Flex gasket is capable of effecting a seal over a wide range of applied stress making the product suitable for use in an extensive range of standard and non-standard bolted connections. Soft compressive materials and a relatively wide sealing face make the product more robust with regard to use on a wide range of flange sealing face conditions when compared with 'O' Ring and/or spring energised based gasket insulation technology.

**Operational pressure range:**  
**Maximum flange pressure class:**  
300 Class ASME 16.5  
EN1514-1 PN40

**Operational temperature range:**  
Up to 150°C

The SIGMA® 500 material is suitable for sealing all chemicals across the whole pH range (0-14) with the exception of molten alkali metals, fluorine gas or hydrogen fluoride. The insulating gasket and washers have been designed and developed for use in pipelines that require cathodic protection. This special design exceeds the requirements of 'Saudi Aramco Std. 02-SAMSS-010'.

**Insulating Gasket Properties:**

Gasket Thickness	3mm
Gasket Factor (m)	1.4
Min Design Seating Stress (y)	1885 psi
Minimum Temperature	-200°C
Maximum Temperature	260°C
Dielectric Strength	9.8 kV/mm

This Data Sheet refers to the material as supplied. The information contained herein is given in good faith, but no liability will be accepted by the Company in relation to same.

We reserve the right to change the details given on this Data Sheet as additional information is acquired. Customers requiring the latest version of this Data Sheet should contact our Applications Engineering Department.

The information given and, in particular, any parameters, should be used for guidance purposes only. The Company does not give any warranty that the product will be suitable for the use intended by the customer.

## PRODUCT DATASHEET

### Insulating Sleeves / Tubes – Thermal / Dielectric Properties:

G10	– Temperature Range	150°C
G10	– Dielectric Strength	19.7 kV/mm

(Note: Other materials, for example Mylar, Phenolic and Nomex, are available on request.)

### Insulating Washers - Thermal / Dielectric Properties:

G10	– Temperature Range	150°C
	– Dielectric Strength	19.5 kV/mm

### Metallic Backing Washers:

Stainless Steel 316 (as standard)	3mm thk.
-----------------------------------	----------

(Note: Other metals can be provided to suit the application)

### General Assembly:

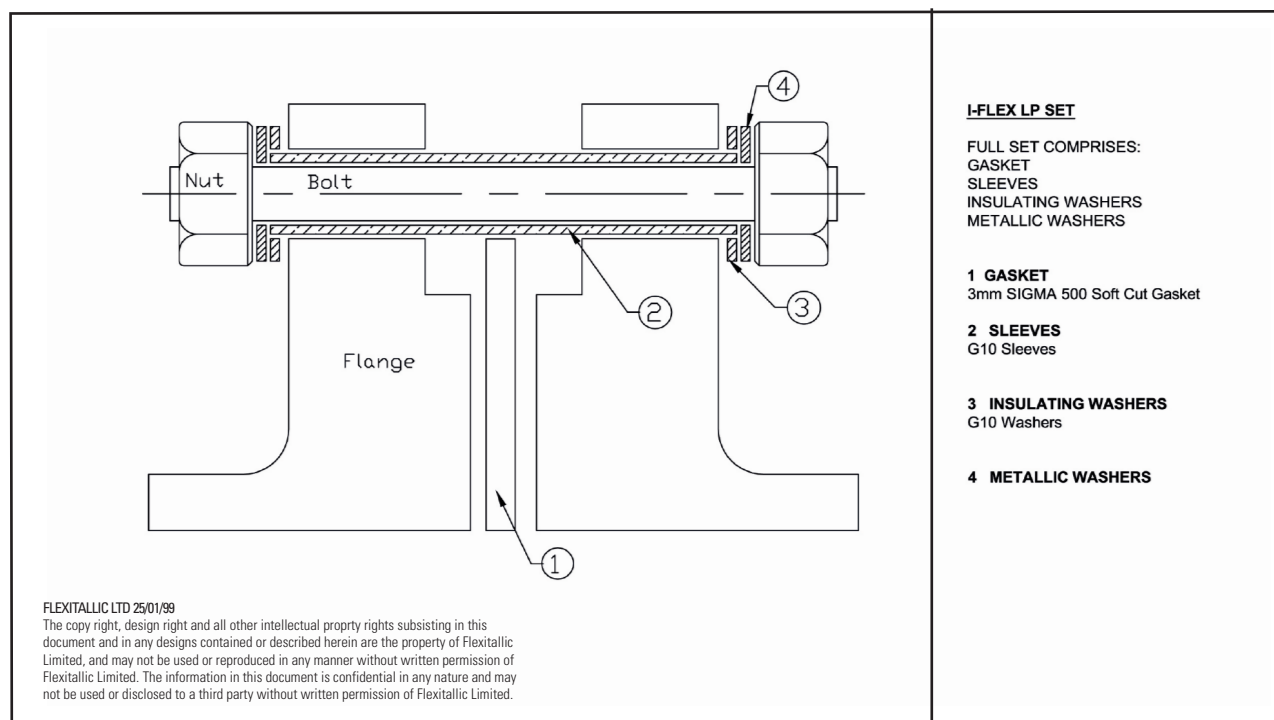

### The Standard I-Flex Set comprises of the following components:

I-Flex Insulating Gasket	soft cut	– up to 150/300 class PN40	1 pc
G10 Insulating Sleeves			1 pc per flange bolt
G10 Insulating Washers			2 pc's per flange bolt
Backing Washers 316SS			2 pc's per flange bolt

Maximum temperature: 150°C

Please contact the Flexitallic Applications Engineering Team when specific operating parameters requires confirmation of appropriate materials.